

KIENE®

DIESEL ACCESSORIES, INC.

CYLINDER PRESSURE INDICATORS

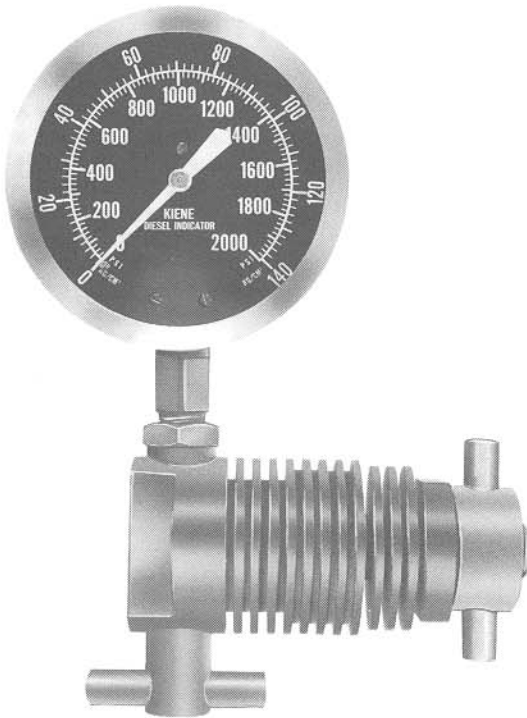

INSTALLATION AND OPERATION

The indicator is installed on the indicator valve using the wing nut and plug (1). When the indicator valve is opened, the check valve (4) will rise and fall with the engine cylinder pressure, trapping the maximum pressure in the pressure chamber (2), and this average maximum pressure can be read directly on the dual scale pressure gauge (3). The gauge may be conveniently positioned for ease of reading by loosening the gauge bolt wing nut (5). The pressure in the pressure chamber (2) and on the pressure gauge (3) is removed by loosening the wing nut (5).

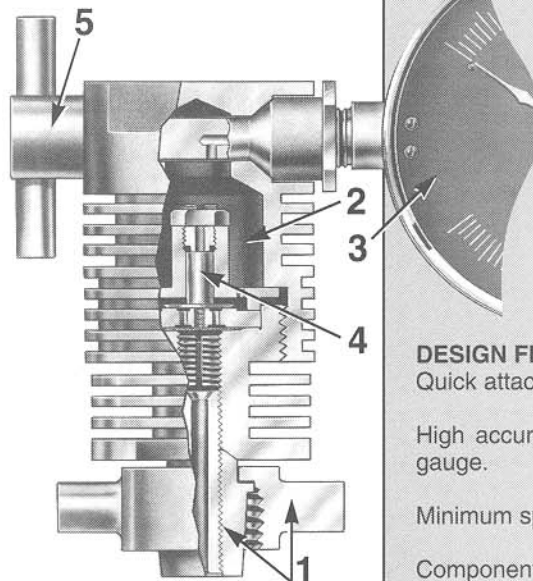

MEASURE FIRING AND COMPRESSION PRESSURE ON DIESEL AND NATURAL GAS ENGINES

Efficient diesel engine operation is important because it insures reduced maintenance and maximizes fuel economy and engine availability.

Diesel and natural gas engines operate most efficiently when each cylinder carries an equal portion of the total load. The most reliable method of measuring cylinder load is to measure the firing pressure of each cylinder.

The Kiene Cylinder Pressure Indicator has been the instrument of choice for engine owners and operators, engine manufacturers, and service personnel for over fifty years. By utilizing the Kiene Indicator, over and underloaded cylinders can be identified and the necessary corrective action initiated to maximize engine and/or cylinder operation.

The indicator attaches quickly and conveniently to any standard indicator valve. The "trapped pressure" design utilizes a light weight check valve, reducing the effects of inertia, insuring maintenance free operation and permitting the averaging of several pressure readings. The liquid filled gauge provides a steady pointer for quick, accurate cylinder pressure readings in either psi or bars. The design of the indicator allows installation in a minimum amount of space, and attachment to the indicator valve in any position. The gauge can also be rotated at any point in a 360 degree arc for convenient reading.

If cylinder firing pressures are not being utilized to determine engine operation and condition, engine operation and its operating costs may be adversely affected.

Contact Kiene to learn how the Kiene Cylinder Pressure Indicator can improve your engine operation and reduce operating costs.

DESIGN FEATURES

Quick attachment to standard indicator valves.

High accuracy, liquid-filled, dual scale pressure gauge.

Minimum space required for installation.

Components designed for low maintenance, long life operation.

K-INSTRUMENT ORDERING INFORMATION



MODEL K-100 – Indicator, equipped with 3 $\frac{1}{2}$ " xytel nylon case, threaded bezel, liquid filled bourdon gauge, dual range 0-2000 psi and 0-140 bars, complete with carrying case and service tools.

MODEL K-107 – Indicator, equipped with 3 $\frac{1}{2}$ " xytel nylon case, threaded bezel, liquid filled bourdon gauge, dual range 0-3000 psi and 0-210 bars, complete with carrying case and service tools.

MODEL K-108 – Indicator, equipped with 3 $\frac{1}{2}$ " xytel nylon case, threaded bezel, liquid filled bourdon gauge, dual range 0-3500 psi and 0-250 bars, complete with carrying case and service tools.

KIENE INDICATOR VALVES FOR 2 OR 4 STROKE GAS OR DIESEL ENGINES



V-LINE

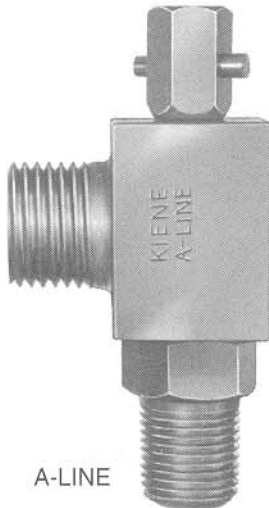

A-LINE

During development of its indicator valve, Kiene recognized that a new design concept was necessary to improve the operational characteristics of valve. The major problems were (1) restrictive installation space, (2) valve seat deterioration due to high combustion temperatures, and (3) uncontrolled valve opening.

The installation of conventional indicator valves required a clearance in excess of 3 inches. By redesigning the gas passage and using a 60 degree valve stem angle, Kiene produced an indicator valve requiring only 1 $\frac{5}{8}$ inches of clearance for installation purposes.

A new concept in valve seat and valve stem design eliminated valve seat deterioration by shielding the seat area from the high combustion temperatures inherent in diesel and natural gas engines.

Kiene indicator valves features an original concept of "opening against and closing with engine cylinder pressure," so that any movement of the valve stem due to engine vibration, tightens the valve stem against its seat, excluding the possibility of the valve opening during engine operation.

All Kiene V-Line (Leaflet 150) and A-Line (Leaflet 155) Valves feature low initial cost, trouble free performance and ease of operation. Kiene valves have endurance and reliability unmatched by other valves available today.

For specific engine applications send for Leaflet 150 or 155.